

Product Description

Thank you for purchasing Solid Apollo's Waterproof 120V AC DMX to RGBW Decoder. It is a new standard in DMX to RGB 4 Channel DMX Interfaces.

If you currently have a DMX512 controller or any DMX capable control unit, this is the perfect device for addressing 120V LED RGB products like our RGB Neon LED and RGB Driverless LED Strip Lights. You may also easily daisy-chain multiple units for additional RGBW outputs.

The Waterproof 120V AC DMX-RGBW Decoder converts DMX signals to RGBW in a seamless and easy-to-use fashion. This second generation DMX- RGBW decoder has a 3-digit LED display which makes it simple to input the units settings.

Thanks to its IP67 full waterproof encasing, the Waterproof 120V AC DMX- RGBW Decoder is ready for all weather conditions without the need of a protective box.



Waterproof 120V AC DMX-RGBW Decoder

Manual will Review

- Installation Process
- Product Features and Detailed Functionality
- Technical Information
- Troubleshooting

Main Functions

- Converts DMX signals to RGBW
- Fully waterproof design - IP67
- Easy to use digital readout
- DMX512 compatible
- 600W at 120V and 1200W at 240V DC
- DMX address selection thru LED display
- DMX IN and OUT
- RoHS, CE certificate
- 3 year warranty
- Comes with an 18in DMX adapter

Product Features

- **DMX Control**
The Waterproof 120V AC DMX-RGBW Decoder comes embedded with DMX512 protocol that will allow you to use a DMX512 controller or a DMX capable control unit such as Solid Apollo's LEDMotion 512, DMX Boss Wi-Fi Controller, Duet DMX & Wireless RGB-W In-Wall Controller, and more. Furthermore, you can easily daisy-chain the Waterproof 120VAC DMX-RGBW Decoder to multiple decoders enabling them to run the same program seamlessly.

Installation

The Waterproof 120V AC DMX-RGBW Decoder is easy to install and will operate Solid Apollo's Driverless RGB LED Strips or RGB Neon LED Strip Lights that work at line voltage of 120V AC. The Wiring Diagram below gives you an overview guide on how to correctly wire your Waterproof 120V AC DMX-RGBW Decoder to each individual component.

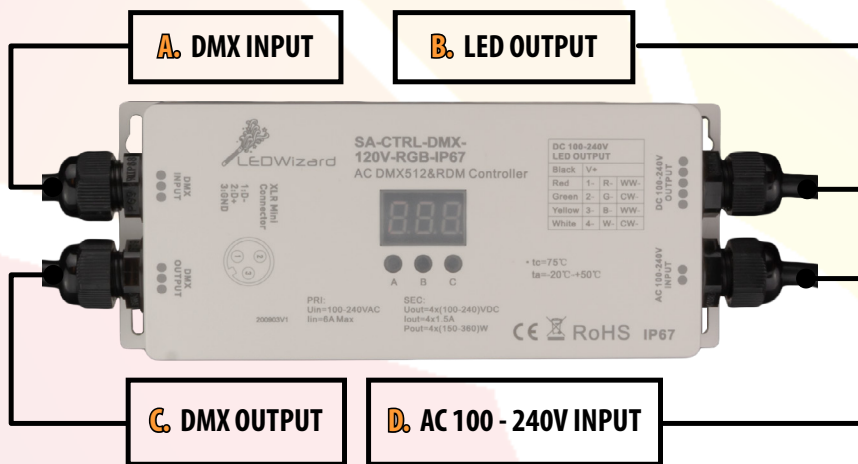

Figure 1.

DMX INPUT / OUTPUT Color Code

White : DMX + / D + (Positive)
Green : DMX - / D - (Negative)
Black : Common / Ground

Figure 2.

RGB - LED OUTPUT Color Code

Black : V + **Red** : R -
Green : G - **Yellow** : B -
White : W -

A. DMX INPUT

The DMX INPUT has a dual purpose: if you're only using a single Waterproof 120V AC DMX-RGBW Decoder you would use the DMX INPUT to connect your DMX512 Controller or your DMX capable control unit to control your LED RGBW lighting fixture. You can also daisy-chain to multiple Waterproof 120V AC DMX-RGBW Decoders. Simply connect the **DMX OUTPUT** of the first decoder to the **DMX INPUT** of the second decoder (as shown on pg.3). You would repeat these steps for additional decoders.

B. LED OUTPUT

The LED OUTPUT is where you hard-wire your 120V RGBW LED lighting fixture. Please follow the color code as shown in Figure 2 and check that all wires from the Waterproof 120V AC DMX-RGBW Decoder and your 120V LED lighting fixture are correctly wired respectively to each other.

***Please Note:** In order for your RGBW LED lighting fixture to have a full waterproof connection, you would have to install a heat sink (not included) that covers the LED OUTPUT and RGBW LED lighting fixture wires. Alternatively you can also use our **RGB Outdoor Waterproof Connector (SKU: SA-LS-4-PIN-GLAND)**. We offer in-store installation should you need it. Please contact us for more information.

C. DMX OUTPUT

The DMX OUTPUT is used for daisy-chaining multiple Waterproof 120V AC DMX-RGBW Decoder (as shown on pg.3).

D. AC 100 - 240V INPUT

The AC 100 - 240V INPUT comes ready to plug in to any household outlet.

DMX Control Wiring Diagram

The Waterproof 120V AC DMX-RGBW Decoder can be daisy-chained with additional, optional decoders to run different programs simultaneously from a DMX master console.

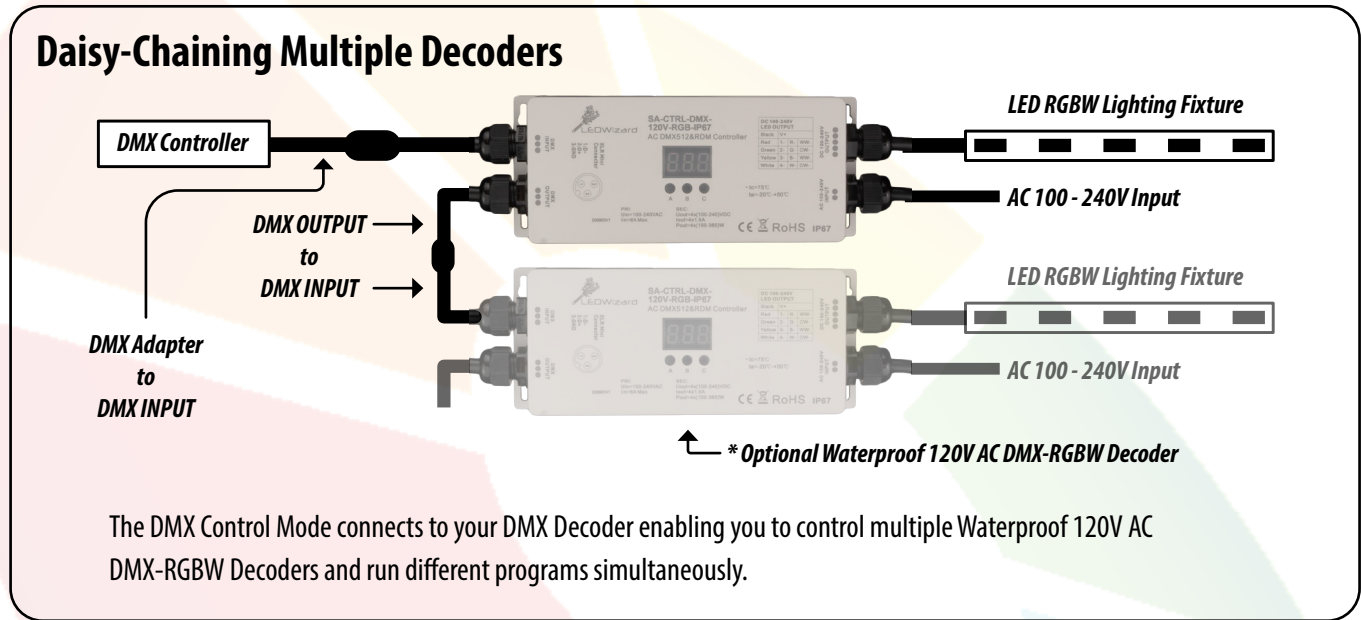

Supported RDM PIDs

The Waterproof 120V AC DMX-RGBW Decoder supports the following RDM PIDs:

- DISC_UNIQUE_BRANCH
- DISC_MUTE
- DISC_UN_MUTE
- DEVICE_INFO
- DMX_START_ADDRESS
- IDENTIFY_DEVICE
- SOFTWARE_VERSION_LABEL
- DMX_PERSONALITY
- DMX_PERSONALITY_DESCRIPTION
- SLOT_INFO
- SLOT_DESCRIPTION
- MANUFACTURER_LABEL
- SUPPORTED_PARAMETERS

Product Installation

Step 1: Confirm DMX Connection

After installing DMX input, output, and LED output, turn on the decoder by plugging the unit in to a 100-240V outlet.

When a DMX signal is connected properly, the display will show a red signal indicator dot after the first digit position (see diagram A).

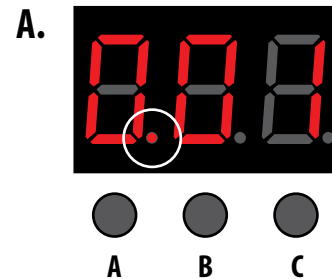

Step 2: Assigning a DMX Address

The factory default DMX address is 001. Press and hold any one of the buttons until the digital display flashes. When done correctly you will now be able to set an address to the DMX-RGBW Decoder.

- B.** Set the desired address by using button A to set the hundreds position, button B to set the tens position, and button C to set the ones position. For example, to set the address as 418, press button A four times, button B one time, and button C seven times. Hold any button for >3 seconds to confirm the setting.

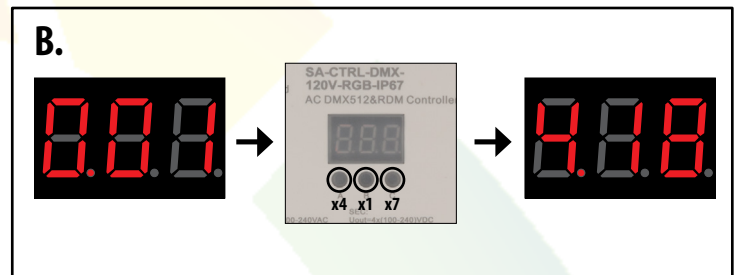

Step 3: Selecting 1-4 Channel Operation

- C.** Easily switch between 1, 2, 3, and 4 channel operation depending on the type of fixture you are using.

- 1 Channel** - for use with single color LED fixtures
- 2 Channel** - for use with Dynamic White or other two channel fixtures
- 3 Channel** - Standard RGB fixtures
- 4 Channel** - for use with RGBW, RGBA or other four channel fixtures

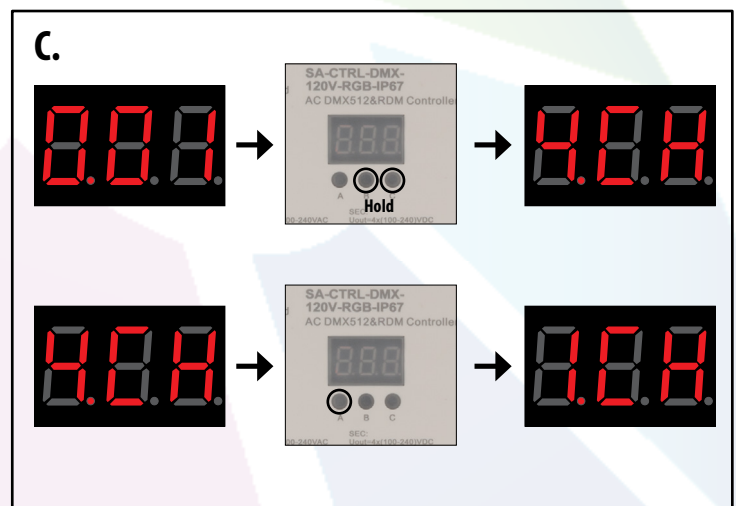

The factory default Channel setting is 4 Channels. To choose DMX channels, press and hold buttons B and C simultaneously for over three seconds until the display flashed CH. Press button A to choose 1, 2, 3, or 4 channels. Press and hold button A for >3 seconds to confirm the setting.

Keep in mind channel selection will determine the DMX address of the output. For example, if DMX address of the unit is set to 001:

- 1CH** - 1 DMX address for all the output channels which will all be addressed 001
- 2CH** - 2 DMX addresses, outputs 1 and 3 will be addressed 001, outputs 2 and 4 will be addressed 002
- 3CH** - 3 DMX addresses, outputs 1 and 2 will be addressed 001, 002 respectively, outputs 3 and 4 will be addressed 003
- 4CH** - 4 DMX addresses, outputs 1, 2, 3, and 4 will be addressed 001, 002, 003, and 004 respectively.

Step 4: Selecting the Refresh Rate

What is a Refresh Rate

Powering LEDs with driver refresh rates below 240Hz can interfere with video signals, causing phase distortion or flickering when the light source is in the camera's field of view. A low refresh rate can also cause a shutter effect when an LED is physically in motion.

This 4 channel DMX to RGBW decoder can process pulse width modulation (PWM) refresh rates up to 35KHz with no image flickering whatsoever, making it the perfect choice for studio accent lighting, stage lighting, or any environment where video is to be broadcast or recorded.

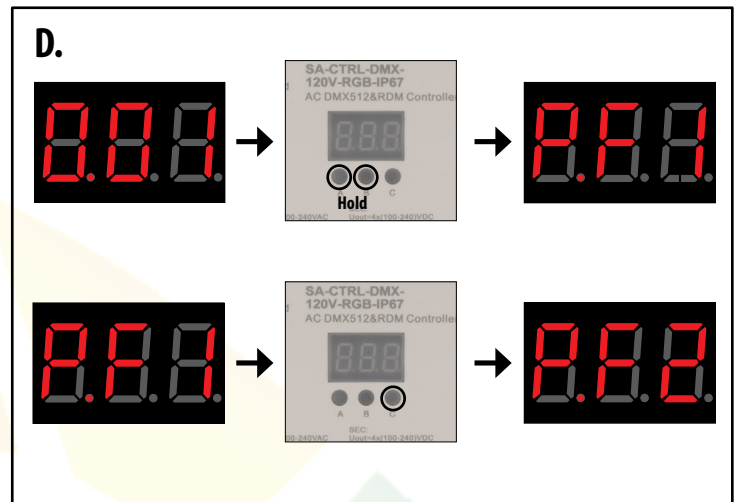

D. Setting the Refresh Rate

To change the refresh rate:

1. Press and hold buttons A and B simultaneously for over three seconds until the display flashes PF1, the factory default setting.
2. Press button C to cycle through the unit's frequencies, 0-9 and A-J which stand for the following frequencies: 0=500Hz, 1=1KHz, 2=2KHz, ... 9=9KHz, A=10KHz, B=12KHz, C=14KHz, D=16KHz, E=18KHz, F=20KHz, H=25KHz, J=35KHz
3. Press and hold button C for >3 seconds to confirm the setting.

Step 2: Choosing a Dimming Curve Gamma Value

E. What is a Dimming Curve

The dimming curve indicates the rate at which a lighting fixture will dim between 0% and 100%. A linear curve indicates an equal rate between the highest and lowest values, making it a good choice for software-based automated control. A logarithmic curve indicates a slower dimming rate at the highest and lowest ranges, allowing for finer control in the upper and lower levels and making it a good choice for non-automated or "static" light settings where more control over dimming is needed.

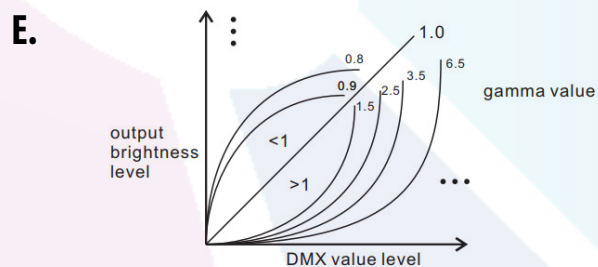

F. To change the dimming curve gamma value:

1. Press and hold down all buttons, A, B, and C, simultaneously for over 3 seconds until the display flashes g1.0, the factory default setting.
2. Use uttons B and C to change the corresponding digits to assign a value from 0.1-9.9
3. Press and hold buttons B and C for >3 seconds to confirm the setting.

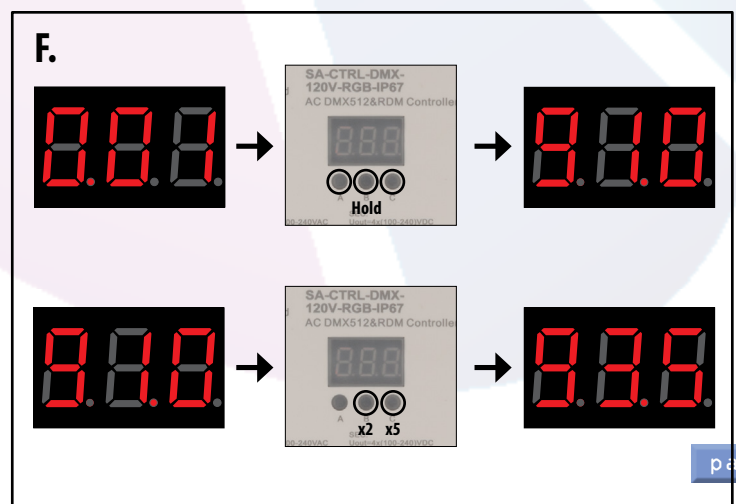

Restore to Factory Default Settings

To restore to factory default settings, hold buttons A and C simultaneously for over three seconds until the display flashes. All settings will be restored to default:

DMX Address: 001

DMX Channel: 4CH

PWM Frequency: PF1

Gamma Curve: g1.0

Technical Information

Dimmable : **Yes**

Operating Voltage : **100 - 240V DC**

Max Power : **720W @ 120V DC & 1440W @ 240V DC**

Warranty : **3 Years**

Weight : **2.25 lbs**

Size : **L: 7.1in x W: 2.9in x H: 1.5in**

IP Rating : **IP67**

Control system : **DMX512**

RGB Channels : **4**

DMX Channels : **512**

Working Temperature : **-4 to 122 F**

Certificates : **CE, RoHS**

Troubleshooting

DMX signal not received

1. First check to make sure your DMX wires are connected to the DMX IN, and not to the DMX OUT ports on the left side of your decoder. The DMX OUT ports do not receive signal and will not work as inputs from a DMX controller (refer to the diagram on page 3).
2. Be sure the decoder is set to the correct channel selection based on your LED lighting fixture, and that you have correctly inputted the specified DMX address (refer to page 4 for setting up DMX Address).

RGBW LED lights are not turning on when the Waterproof 120V AC DMX-RGBW Decoder Receiver is plugged in.

1. Please revert back to the wiring diagram (Page 2) and check your wiring connection to see if the fixture's wires match their corresponding decoder wire (positive to positive and negative to negative). If you have installed the RGBW Outdoor Waterproof Connector, please make sure that the RGBW wires are installed correctly onto their terminals and in relation to their corresponding wire.

****Should you have any questions about installation, troubleshooting, and other concerns, please don't hesitate to call us at 425.582.7533 and we will be glad to assist you.***