

Manual Content

- Product Information
- Product Diagram
- Product Wiring & Installation
- Product Operation Guide
- Product Troubleshooting and Safety

Product Description

Solid Apollo's ProAV 4 Channel DMX to RGB-W Controller is an excellent affordable choice for lighting and video professionals who require a very smooth color changing effect without a noticeable refresh rate.

It converts DMX signal to RGBW and it is highly configurable with several adjustable settings. Thanks to the crisp LED display screen, these settings can be easily adjusted to give you the best output for your application.

In addition, this heavy-duty DMX512 controller is constructed with a robust metal housing that has mounting tabs on each side easy installation.

The ProAV is designed with an RJ45 input/output port for easy connectivity. It can easily be daisy chained (inter-connected) with multiple units or connect to a DMX Console.



Product Features

- DMX512 to RGBW Controller
- Powerful 4 X 8A Outputs
- RJ45 in/out port for easy DMX connection
- Maximum power of 1152W at 36V DC
- Output refresh rates of 200 & 1500Hz
- Visual display for easy configuration
- Linear and logarithmic dimming
- Excellent for audiovisual applications
- Ability to combine output channels

Product Specs

- Dimmable : Yes
- Input Voltage : 12V - 36V DC
- Max Power : 384W@12V DC - 1152W@36V
- Max Amp : 4 x 8A
- Control System : DMX512
- DMX Channels : 512
- PWM Refresh Rate : 200Hz - 1500Hz
- Dimming Curve : 0.1 - 9.9 Gamma
- Resolution : 8-bit / 16-bit
- Weight : 0.75 lbs
- Dimension : 6.5" x 2.3" x 1.2"
- Product Color : Black
- Product Material : Metal
- Working Temperature : -4°F - 122°F
- Warranty : 3 Years
- Certificates : CE, RoHS

Product Wiring Diagram

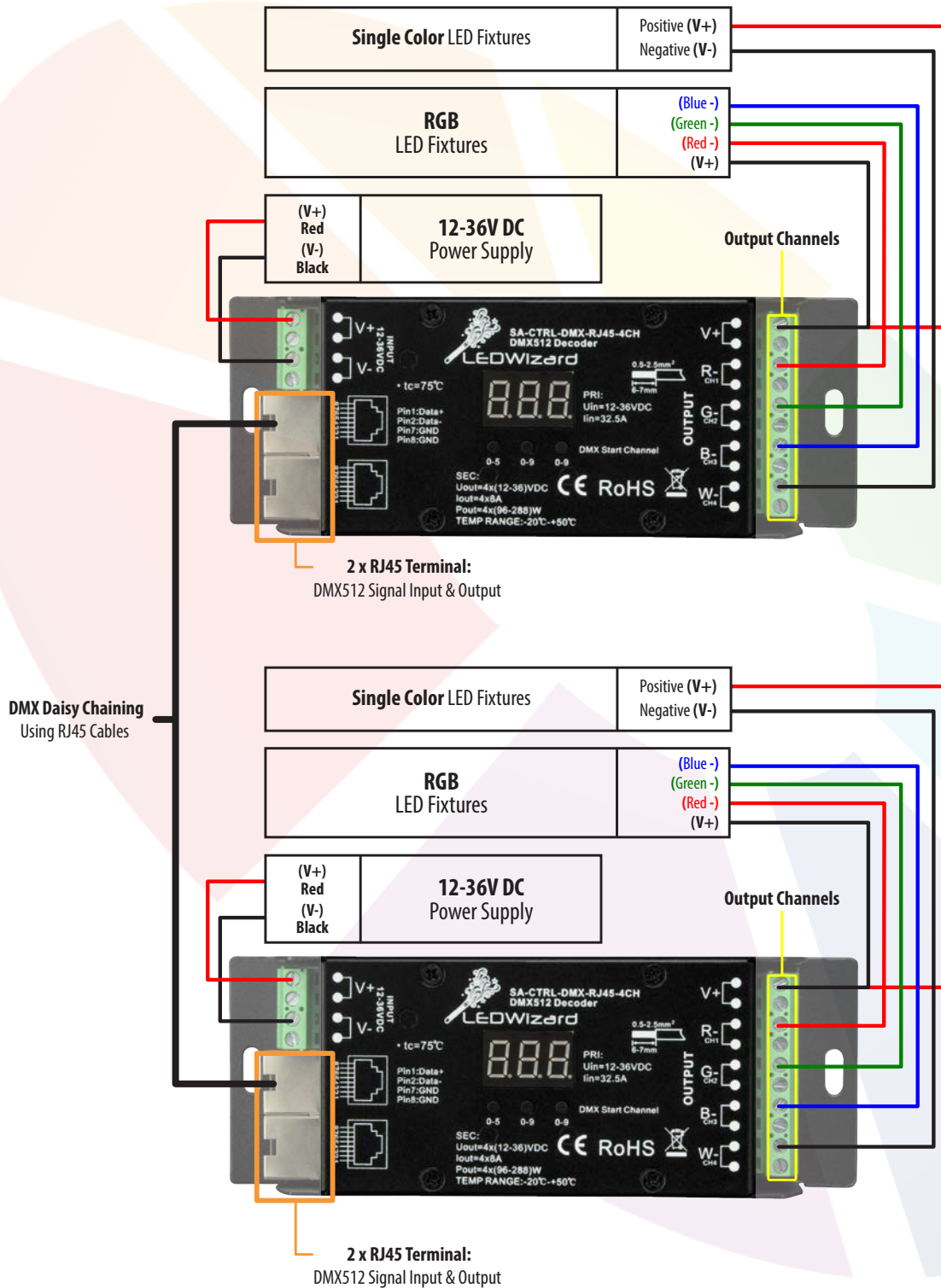

Product Wiring & Installation

In order to successfully and effectively be able to use Solid Apollo's ProAv 4 Channel DMX to RGBW controller, it will have to be properly installed/wired. The correct amount of power has to be supplied and proper connections made between DMX Console or Controller, Light Fixtures, or LED Strips. Here is a guide on how to correctly install the product:

1. Ensure that the necessary accessories (DC Wires and DC-Plug – if necessary, and RJ45 Cable) are available.
2. Verify that the Power Supply has the right voltage and Wattage required for the LED fixture.

3. To add power to the Controller,

- a. Strip off about ¼-inch of the plastic jacket from the ends of the Power Supply's wires. Twist each wire to bind the strands together for a better installation.
- b. Open the green terminal-block slots on the "INPUT" side of the controller using a flat-head screw driver.
- c. Connect the Red (positive) wire of the Power Supply to the **V+** of the "INPUT" screw-terminals. This is done by installing the wire into the slot on the side and then tightening the screw at the top. Then connect the Black (negative) wire to the **V-** in a similar manner.

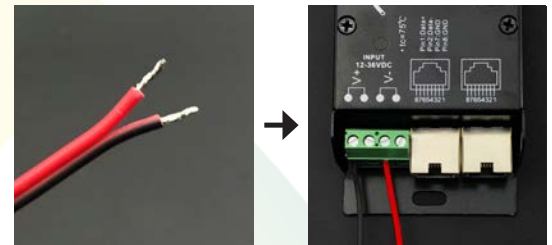

4. To connect the LED fixture to the Controller,

- a. Strip off about ¼-inch of the plastic jacket from the ends of the LED Fixture's wires. Twist each wire to bind the strands together for a better installation.
- b. Open the green terminal-block slots on the "OUTPUT" side of the controller using a flat-head screw driver.
- c. Connect the RGBW fixture's wires to the "OUTPUT" screw-terminals of the controller. This is done by installing each wire in the corresponding slot (on the side) and tightening the screw at the top (Red goes to output **R**; Green to output **G**; Blue to output **B**, White to output **W**, and the positive wire to **V+**).

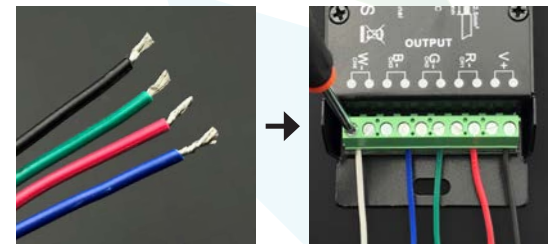

5. Plug the power supply to a power outlet and power up. The display screen on the controller will show **A001** where 001 is the DMX starting address.

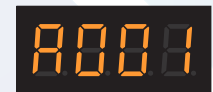

6. Finally, connect the DMX Control System to the controller (if applicable) using RJ45 cable.

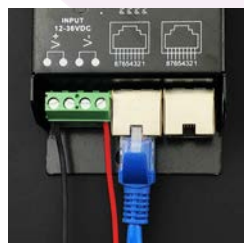

7. If cascading/daisy-chaining multiple units, use an RJ45 cable to connect to between one controller unit and another (please refer to the wiring diagram - pg2).

Note: Always make sure that the Controller is powered on first before sending DMX signals.

Product Operation Guide

Buttons Configuration



Button 1: This button is used with button 3 to select the Frequency function (push and hold).

Button 2: This button is used with button 1 to select the Output function (push and hold).

Button 3: This button is used for selecting the DMX Address function (push and hold).

Functions



Means **DMX Address** which can be set from 001 to 512.



Means **Dimming Type** of linear or logarithmic.



Means **Output Channels** which can be set from 1 to 4.



Means **Pulse Width Modulation Frequency** of 200Hz or 1500Hz.

Functions Setting

DMX Address

When the controller is powered ON, the display shows an **001** address which is the default starting address. To change or set to a different address, press and hold the **button 3** (see Button Configuration above) for 3 seconds and the display will start blinking. Then use the three buttons to set the desired address. **Button 2** and **3** will change the second and last digits respectively between 0 and 9, and the **button 1** will change the first digit between 0 and 5. Once the desired starting address is set, press and hold any button for 3 seconds to **save**.

For example, to set a DMX starting address to 235. Press and hold button 3 until the display starts to blink, then use button 1 to set the first digit to 2, then button 2 to set the second digit to 3, and button 3 to set the third digit to 5 (this will give 235). Then press and hold any button for 3 seconds and the display will save the address and stop blinking.

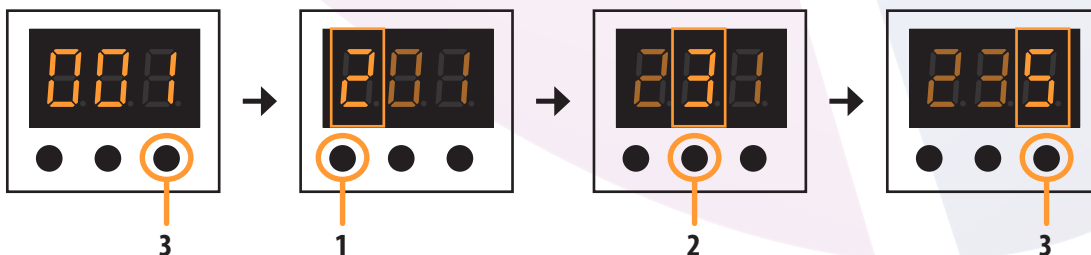

Product Operation Guide (continued)

LED Output Channel

With this function, you can utilize all the four LED outputs of the controller using four, less than four, or more than four DMX addresses. For example, when this function is changed to CH2 it lets you control the four outputs with just two DMX addresses by merging outputs R and B into one and outputs G and W into another.

To change the output channel, press and hold **button 2** and **3** simultaneously for 3 seconds. The display will start blinking with a **4CH** showing. Then use **button 1** to change between channels 1 and 4, and then press any button for 3 seconds to save and exit.

The different output channel mappings at the default starting DMX Address (001) are as follows:

CH01 = 1 DMX Address, all the output channels will be the same address 001.

CH02 = 2 DMX addresses, outputs 1 & 3 will be address 001, output 2 & 4 will be address 002.

CH03 = 3 DMX addresses, outputs 1, 2, 3 will be addresses 001, 002, 003, and output 4 will also be 001.

CH04 = 4 DMX addresses, output 1,2,3, and 4 will be addresses 001, 002, 003, and 004 respectively.

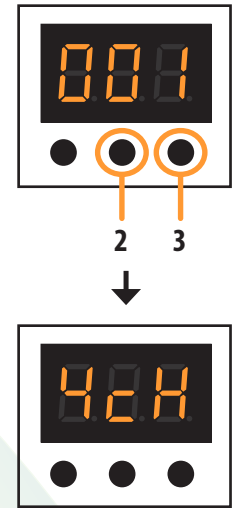

Output PWM Frequency

The Pulse Width Modulation Frequency (refresh rate) can be set as either 200 Hertz to 1500 Hertz for high-quality audiovisual application requirements.

To change the output frequency, press and hold **button 1** and **3** simultaneously for 3 seconds. The display will start blinking with a **P_c** shown (the "P" is the frequency function and "c" is the dimming type). Use **button 1** to change between 1 and 2 where 1 represents the 1500Hz and 2 represents 200Hz. After choosing the desired output frequency setting, press and hold any button for 3 seconds to save and exit.

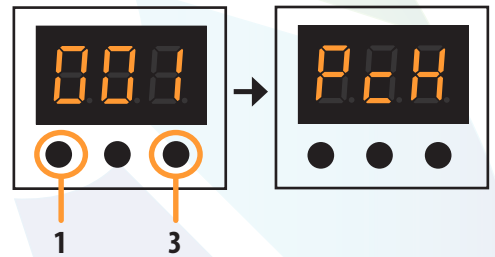

Output Dimming

This function is used to adjust the rate at which the output brightness changes as the lights are dimmed. The controller offers two types of dimming (linear and logarithmic) to help make dimming less sensitive for greater precision in various applications.

To choose a dimming type, press and hold **button 1** and **3** simultaneously for 3 seconds. The display will start blinking with a **P_c** shown (the "P" is the frequency function and "c" is the dimming type). Use **button 3** to change between 1 and 2 where 1 represents logarithmic dimming and 2 represents linear dimming. Then press and hold any button for 3 seconds to save and exit.

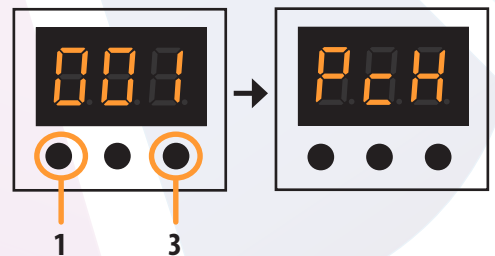

Product Troubleshooting

The following recommendations can help in troubleshooting the ProAV 4 Channel DMX Controller

- 1. Controller does not turn ON after powering up:**
 - A. Ensure that the correct voltage requirement of the controller is supplied.
 - B. Ensure that the wiring of the power supply to the device is correctly done with the Red wire connected to one of the V+ terminals of the controller and the Black wire connected to one of the V- terminal (*Refer to pg.3 for Product Wiring and Installation*).
- 2. Controller is ON but LED fixtures are not:**
 - A. Ensure that the LED fixtures are correctly wired in the "OUTPUT" screw-terminals of the controller (*see wiring diagram -pg.2 or refer to pg.3 for Product Wiring and Installation*).
 - B. Make sure that a compatible DMX control system is used with the controller and correctly connected with an RJ45 cable to control the LED fixtures.
- 3. Controller and LED fixtures are ON but LEDs do not respond to DMX control:**
 - A. Ensure that the proper DMX signal connections are installed between the controller and DMX control system. Use an RJ45 cable to connect the two and make sure to connect to the right ports DMX in/out.

Safety Recommendations

In order to efficiently operate the ProAV controller it is important to correctly and safely install it.

1. Obtain the right accessories (Power Supply, LED Fixtures, Wires, etc.) beforehand.
2. Ensure that the product is properly installed with the right accessories and guidelines.
3. Ensure that wires or cables are correctly connected to their right ports or terminals.
4. Do not try to install/screw-in the LED fixtures wires while the controller is powered.
5. Ensure that the controller is placed or mounted in a dry location.
6. Use only one (not multiple) type of DMX connector/ cable between controller and DMX console.
7. Ensure that peeled (bare) section of the wires going into green screw-terminals are not extending out of the terminal without the insulation.
8. Ensure that the right functions are set in order to better see their effects.
9. Connect and test the controller with the accessories to ensure everything works before final installation.
10. Install the controller at an accessible area for easy settings adjustment when needed.

* *The product is backed by a 3-year warranty. Please refer to www.solidapollo.com for more information on warranty coverage.*