

# NEONARCH 90W LED LIGHTS

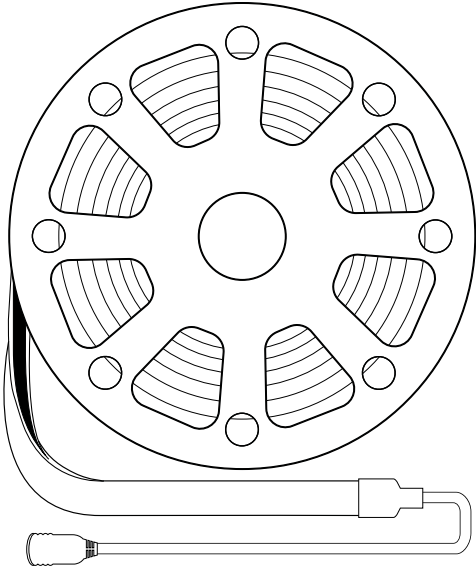

## Product Description

Solid Apollo's NeonArch is a state of the art neon strip simulating the effect and look of neon in a continuous well balanced light. This next generation bendable NeonArch strip is engineered for optimum performance, efficient energy use, and effortless maintenance over traditional glass neon.

The NeonArch is fully dimmable. It features an ultra bright light in an arched shape giving the appearance of seamless, edge to edge light viewable at 180°. The unit body is adaptable and flexible and is top bending in the same direction as the light output. With a width of only half an inch, the NeonArch is made to deliver amazing neon effects in subtle and discreet areas such as the inside of crevices, in-wall applications, and long linear lighting.

- Super Bright Light Viewable at 180°
- 600 Lumens/Foot
- Flexible & Cuttable
- Top Bending
- Cut Points Every 1.3in
- Very High Bond Tape for Waterproof Mounting
- Fully Dimmable
- 16.4ft Spool
- Features a 6.6ft Waterproof Cable w/ Female Barrel Connector
- Low Voltage Product at 24V - 90W Per Spool
- Fully Waterproof, Rated at IP67
- Indoor / Outdoor Application
- Product Comes Ready to Plug & Play
- Perfect for Accent Lighting, Linear Lighting and In-Wall Lighting

## Quick Spec.

- **Fully Dimmable:** Yes
- **Voltage:** 24V DC
- **Beam Angle:** 124°
- **LEDs per Foot:** 64
- **Warranty:** 3 Years
- **Dimensions:** 196.8in x 0.5in x 0.3in
- **Working Temperature:** -10° to 140°F
- **Certifications:** UL, RoHS

**1050 LEDs**  
**16.4ft**



**UP TO 702+**  
**LUMENS / FT**

## NeonArch LED Illustration

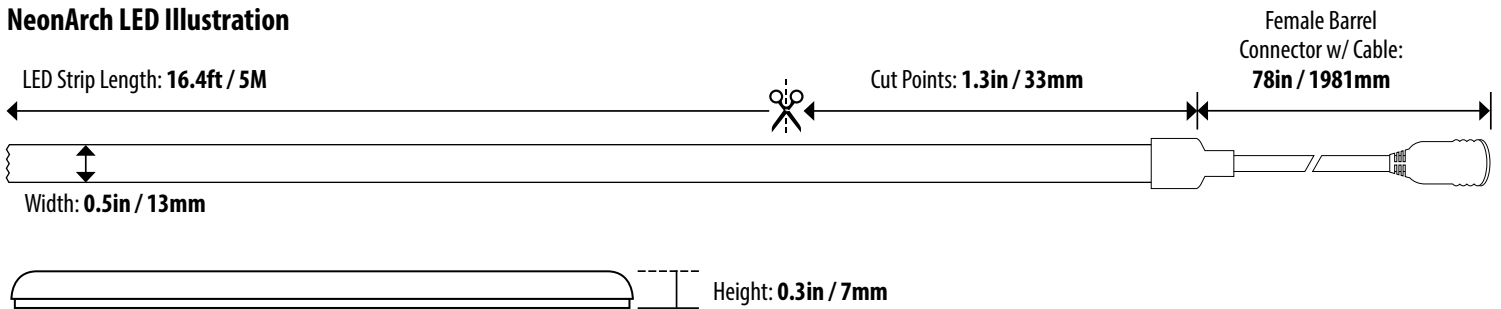

## Technical Information

Available LED Color	SKU#	Temp (K)	Lumens / Ft.	LED Type	Color Rendering Index	Minimum Cut
Candlelight White	SA-NARCH-CLWW	2400K	600	SMD 2835	93+	1.3in / 33mm
Super Warm White	SA-NARCH-SWW	2700K	638	SMD 2835	92+	1.3in / 33mm
Warm White	SA-NARCH-WW	3000K	606	SMD 2835	94+	1.3in / 33mm
Daylight White	SA-NARCH-DLW	4000K	619	SMD 2835	94+	1.3in / 33mm
Natural White	SA-NARCH-NW	5000K	702	SMD 2835	92+	1.3in / 33mm
Red	SA-NARCH-RED	Red	N/A	SMD 2835	N/A	1.3in / 33mm
Green	SA-NARCH-GREEN	Green	N/A	SMD 2835	N/A	1.3in / 33mm
Blue	SA-NARCH-BLUE	Blue	N/A	SMD 2835	N/A	1.3in / 33mm
Amber	SA-NARCH-AMBER	Amber	N/A	SMD 2835	N/A	1.3in / 33mm

## Dimmers

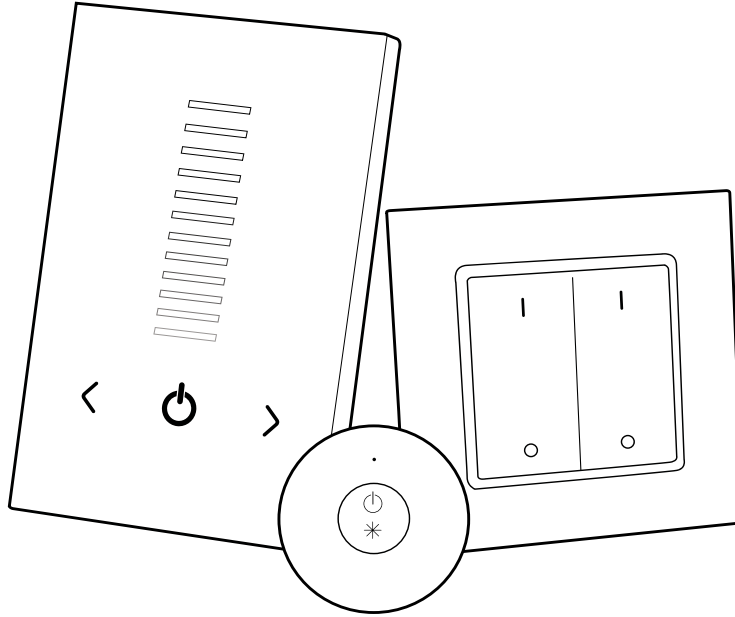

## Power Supplies

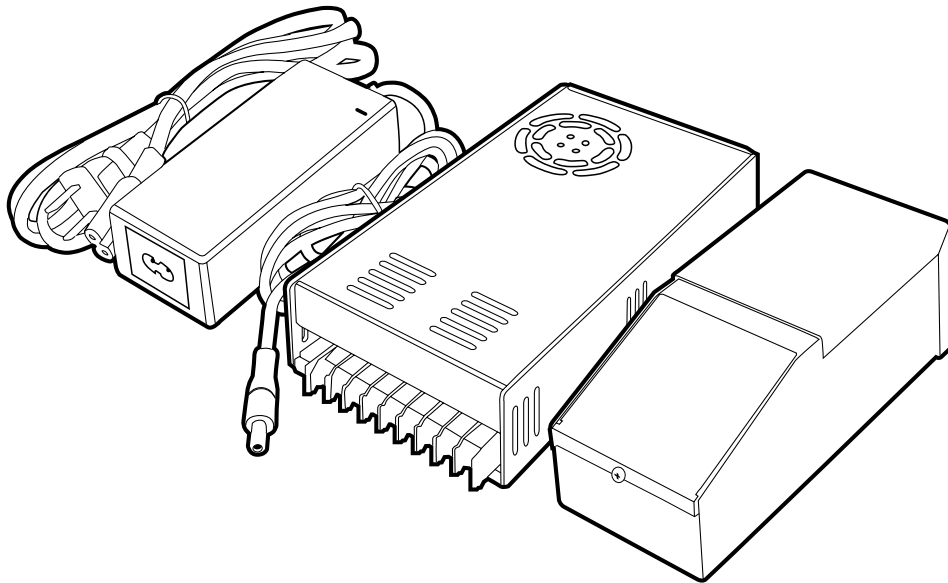

# NEONARCH 90W LED LIGHTS INSTALLATION GUIDE

1. Determine where to install the Neon LED.

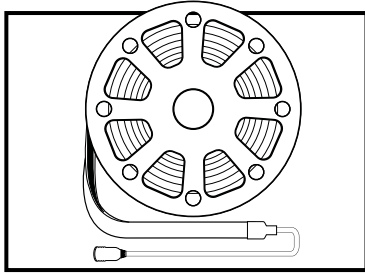

2. Determine the measurement of area where the Neon will be placed.

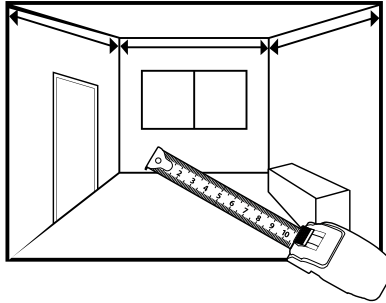

3. If needed, cut additional wire (extending Neon to dimmer).

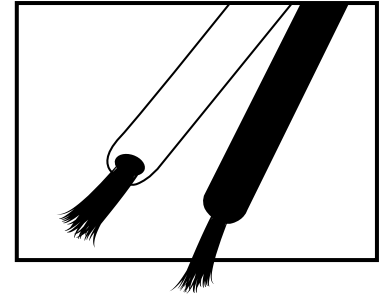

4. A. Cut Neon (at cutting points) to fit or join multiple sections as recommended to cover installation area.

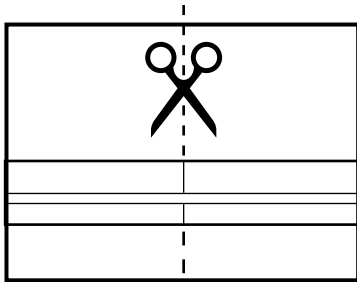

B. If Neon is cut, ensure proper re-waterproofing with an end cap and silicon glue.

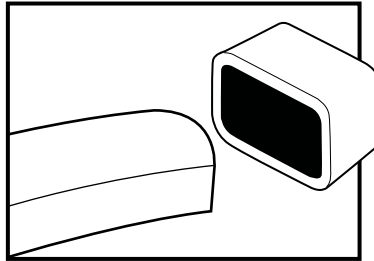

5. If using channels, cut or extend them to fit the size of the installation area.

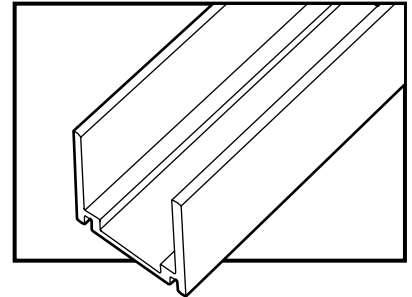

6. Thoroughly clean the surface where the Neon will be mounted.

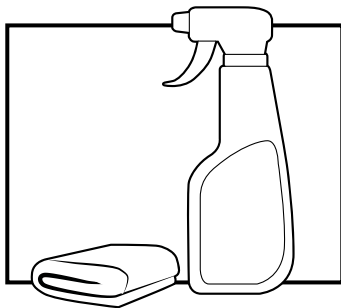

7. If using channels, mount the channel to the surface and gently push the Neon in to the mounted channel.

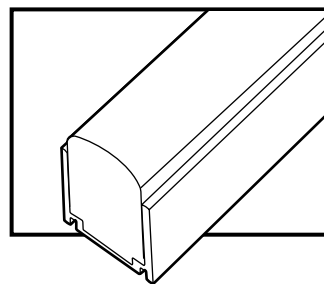

8. Complete the connection/wiring between the plug, optional dimmer, and LED Strips.

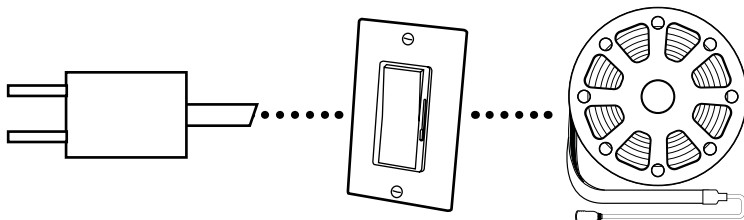

9. Power up and enjoy!

**Note:** If you have questions and concerns regarding the installation process. Please feel free to contact us at 425.582.7533. We will gladly assist you.

# NEONARCH 90W LED LIGHTS WARNINGS

**Do not** power Neon LED still coiled in spool.

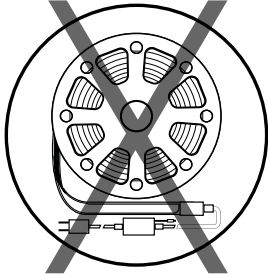

**Do not** bend NeonArch left and right. This light is **TOP BENDING** only.

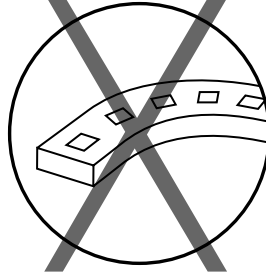

**Do not** bend Neon LED to a diameter less than 1.5 inches.

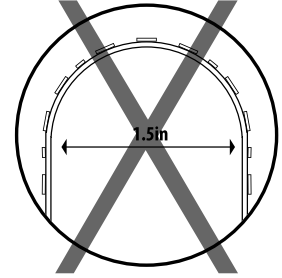

**Do not** fold or crease Neon LED.

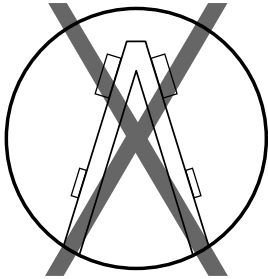

**Do not** twist Neon LED.

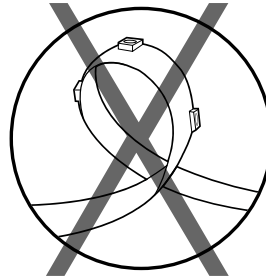

**Do not** cover Neon LED with anything other than LED Channel Diffusers.

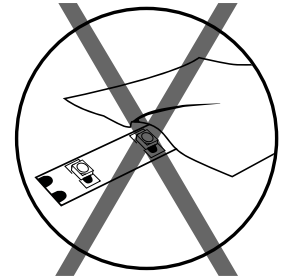

**Do not** put direct excessive pressure on the Neon LED surface.

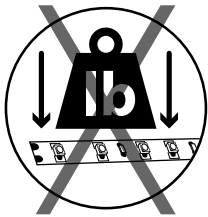

**Do not** cut Neon LED except at designated cutting points.

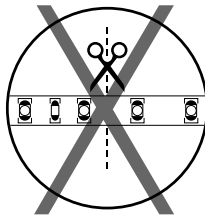

**Do not** position LED at an angled surface where it is pressed.

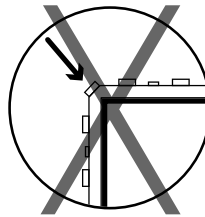

**Do not** submerge Neon LED lights.

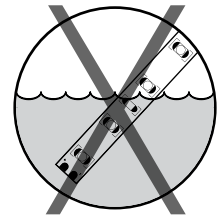

**Do not** connect or interconnect more than 16 feet (5 meters) of LED Strip to one Power Feed.

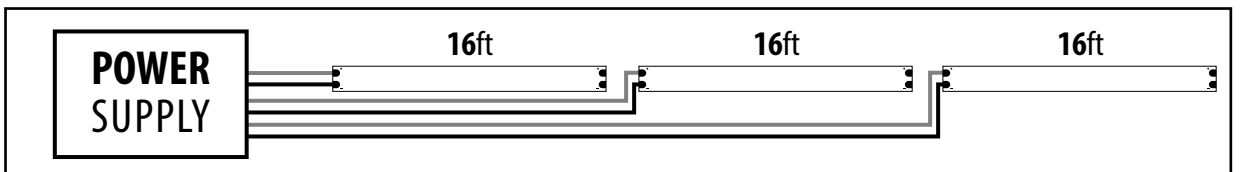
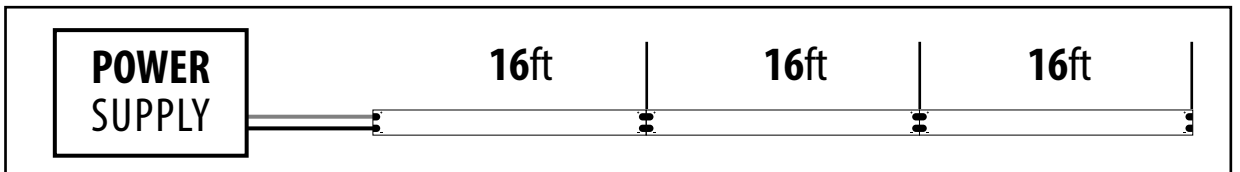

# NEONARCH 90W LED LIGHTS SAFETY & WARRANTY

---

## Safety / Disclosures

1. Install in accordance with the proper installation procedure (See pg. 3).
2. Install in accordance with your national or local electrical code regulations.
3. Suitable for wet locations (IP67 Rated).
4. Do not expose to heat more than the specified temperature ratings.
5. Only install with the required Driver/Power Supply – 24V DC Constant Voltage Driver.
6. Use a separate power feed for each recommended maximum run.
7. Only use cables that are certified for use with external connection of electrical equipment and rated for at least 80°C (176°F)
8. Do not mishandle product or modify beyond the guidelines given as this may void product warranty.
9. Only use with the recommended waterproof accessories and ensure complete waterproofing of any modified sections of the strip.
10. Only use the recommended waterproof accessories and wires to connect between LED strip light, driver, controller, and other devices in between.
11. The output color of the LED Strips may have slight variation from that of the pictures on this document or website due to photo rendering limitations.
12. Design improvements and modification of the products could happen from to time and we reserve the right to do these improvements necessary without any prior notice.

## Warranty

The **NeonArch** 90W LED Lights come with a 3-year limited warranty from the date it is shipped to the customer. This warranty covers the product as long as it is used for the designed purpose and normally operated unless otherwise stated.

Please visit [www.solidapollo.com/returns-amp-warranty.html](http://www.solidapollo.com/returns-amp-warranty.html) for the complete warranty details on the product. For any additional questions about product warranty, feel free to contact customer support at 425.582.7533.